



Australian Model Railway Association

Fine tolerance wheel and track standard

Version 3.1
November 2022

Aim

The aim of this standard is to provide a set of practical dimensions that will give the model railway builder track and wheels that are compatible with the majority of commercially available models and components built to fine scale proportions without the need of using working suspension or compensation.

Introduction

In manufacture it is impossible to produce components to an exact size. This is why we need to build components between a maximum and minimum value. The difference between these values is called the tolerance. A broad generous tolerance is cheaper and easier to produce than a narrow one. Tolerances in this standard have been kept as large as possible without sacrificing quality and fine scale model proportions. Limits are the extremes of size that are allowed for a dimension. Recommended track dimensions are sizes that are within the limits of dimensions. The recommended track tolerances are large enough for the skilled modeler to manufacture track. However, these recommended tolerances are too small for mass produced turnouts and crossings. The recommended wheel dimensions have tolerances broad enough for easy manufacture and are suitable for economic mass production.

Design Notes

Minimum clearance between the wheels outside flange to the track is equal or larger than prototype clearance. Prototype clearances are assumed to be the size of the full size railway wheel / rail divided by the scale assuming each gauge is 1435mm standard gauge. Common model scales are used for this assumption.

The minimum clearance between the wheel back to back and track span is at least half the prototype clearance. Calculations and experience shows it is adequate for turnouts built to scale proportions.

Wheel flange depth has been kept close to 2 times the depth of a scaled down prototype flange except for 0 gauge, where existing commercial fine scale practice uses a smaller flange.

The flange is based on a simplified Australian Prototype ANZR-2 profile. Experiments and analysis shows it to have superior tracking characteristics on sharp curves and uneven track compared to alternative fine scale flange profiles.



Australian Model Railway Association Fine tolerance wheel and track standard

Version 3.1
November 2022

Recommended wheel flange profile

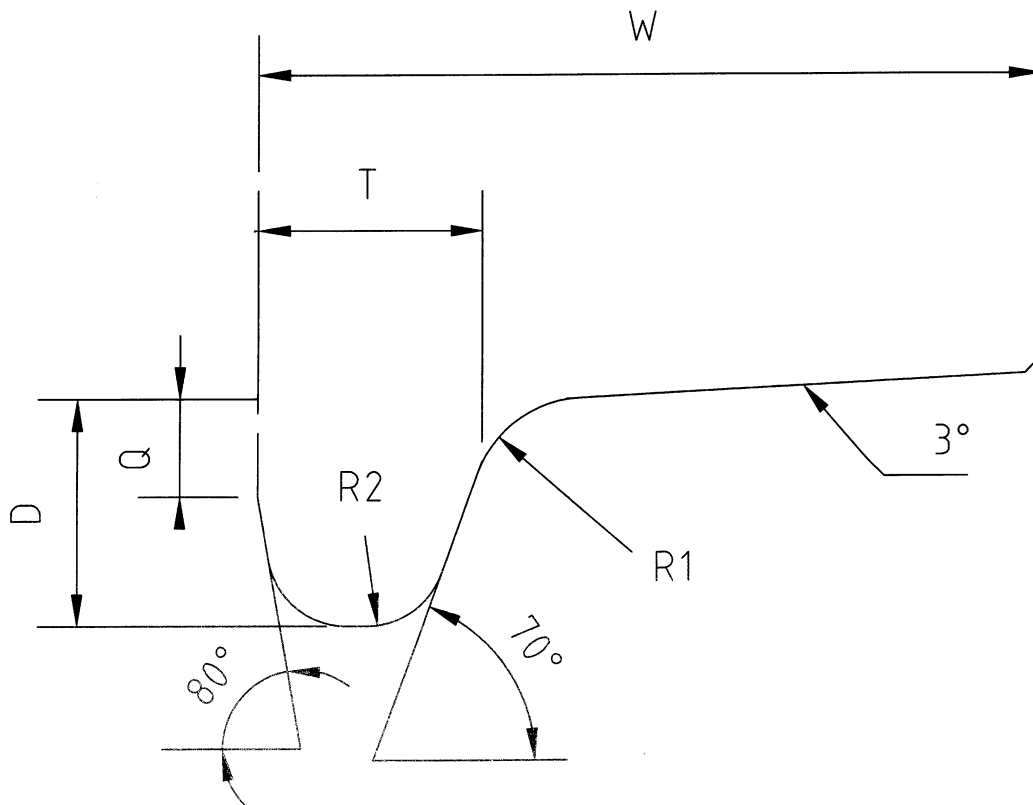

Gauge Name	B		T		D		R1		R2		Q	
	Minimum	Maximum	Minimum	Maximum	Minimum	Maximum	Minimum	Maximum	Minimum	Maximum	Minimum	Maximum
Z	5.34mm	5.44mm	0.41mm	0.46mm	0.41mm	0.46mm	0.05mm	0.21mm	0.06mm	0.16mm	0.10mm	0.21mm
N	7.50mm	7.60mm	0.45mm	0.50mm	0.45mm	0.50mm	0.05mm	0.23mm	0.08mm	0.18mm	0.11mm	0.23mm
TT	10.20mm	10.30mm	0.55mm	0.60mm	0.55mm	0.60mm	0.10mm	0.28mm	0.12mm	0.22mm	0.12mm	0.14mm
H0	14.40mm	14.50mm	0.65mm	0.70mm	0.65mm	0.70mm	0.11mm	0.33mm	0.16mm	0.26mm	0.16mm	0.33mm
EM	16.40mm	16.50mm	0.65mm	0.70mm	0.65mm	0.70mm	0.11mm	0.33mm	0.16mm	0.26mm	0.16mm	0.33mm
S	19.85mm	19.95mm	0.90mm	0.95mm	0.90mm	0.95mm	0.16mm	0.45mm	0.26mm	0.36mm	0.23mm	0.45mm
0	28.80mm	28.90mm	1.00mm	1.10mm	1.00mm	1.10mm	0.23mm	0.50mm	0.20mm	0.40mm	0.25mm	0.50mm
1	39.80mm	40.00mm	1.70mm	1.80mm	1.70mm	1.80mm	0.30mm	0.85mm	0.48mm	0.68mm	0.40mm	0.85mm



Australian Model Railway Association Fine tolerance wheel and track standard

Version 3.1
November 2022

Wheel limits

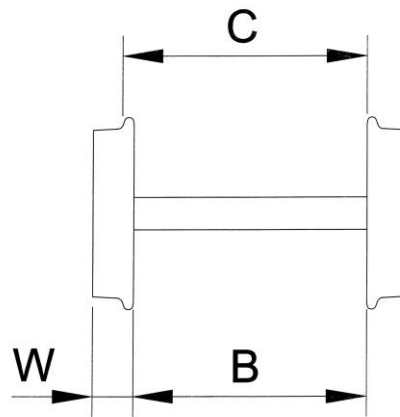

Gauge name	C	B	W
	Check Gauge	Back to Back	Wheel Width
	Maximum	Minimum	Minimum
Z	5.90mm	5.34mm	1.50mm
N	8.10mm	7.50mm	1.60mm
TT	10.90mm	10.20mm	1.90mm
H0	15.20mm	14.40mm	2.10mm
EM	17.20mm	16.40mm	2.10mm
S	20.90mm	19.80mm	2.90mm
0	30.00mm	28.80mm	3.40mm
1	41.80mm	39.80mm	5.20mm



Australian Model Railway Association Fine tolerance wheel and track standard

Version 3.1
November 2022

Recommended crossing V and K (frog) dimensions

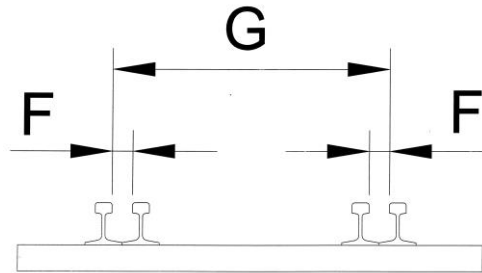

Gauge name	G		F	
	Track gauge		Flange way	
	Minimum	Maximum	Minimum	Maximum
Z	6.65mm	6.70mm	0.70mm	0.75mm
N	8.85mm	8.90mm	0.75mm	0.80mm
TT	11.85mm	11.90mm	0.90mm	0.95mm
H0	16.25mm	16.30mm	1.00mm	1.05mm
EM	18.25mm	18.30mm	1.00mm	1.05mm
S	22.34mm	22.41mm	1.37mm	1.44mm
0	31.70mm	31.80mm	1.60mm	1.70mm
1	44.40mm	44.50mm	2.50mm	2.60mm



Australian Model Railway Association Fine tolerance wheel and track standard

Version 3.1
November 2022

Track limits

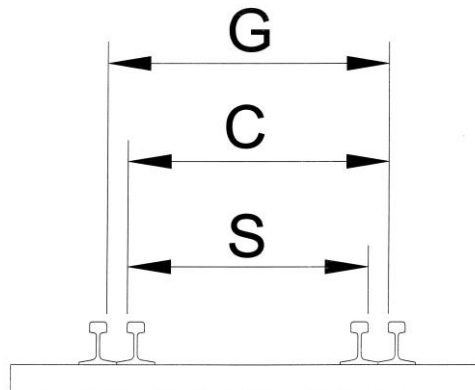

Gauge name	G		C	S
	Track gauge		Check gauge	Span
	Minimum	Maximum	Minimum	Maximum
Z	6.45mm	6.85mm	5.90mm	5.30mm
N	8.85mm	9.30mm	8.10mm	7.45mm
TT	11.70mm	12.30mm	10.90mm	10.10mm
H0	16.20mm	16.80mm	15.20mm	14.30mm
EM	18.20mm	18.80mm	17.20mm	16.30mm
S	22.15mm	22.85mm	20.90mm	19.67mm
0	31.50mm	32.50mm	30.00mm	28.60mm
1	44.10mm	45.40mm	41.80mm	39.50mm



Australian Model Railway Association Fine tolerance wheel and track standard

Version 3.1
November 2022

Track gauge dimensions

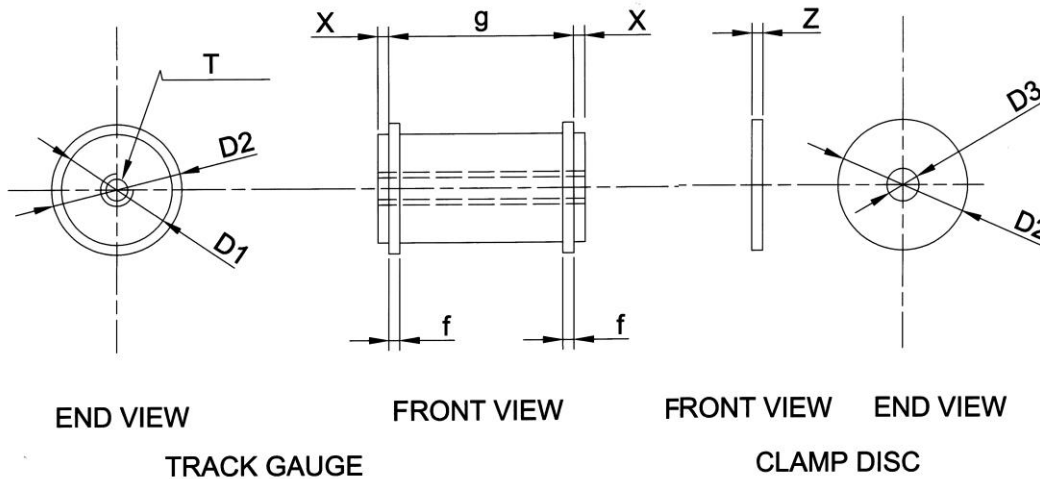

Gauge name	g		f		X		D1		D2		Z
	Minimum	Maximum	Minimum	Maximum	Minimum	Maximum	Minimum	Maximum	Minimum	Maximum	Maximum
Z	6.66mm	6.69mm	0.71mm	0.74mm	0.25mm	0.30mm	4.80mm	4.90mm	5.90mm	6.00mm	0.70mm
N	8.86mm	8.89mm	0.76mm	0.79mm	0.25mm	0.30mm	4.80mm	4.90mm	5.90mm	6.00mm	0.75mm
TT	11.86mm	11.89mm	0.91mm	0.94mm	0.25mm	0.30mm	4.80mm	4.90mm	5.90mm	6.00mm	0.90mm
H0	16.26mm	16.29mm	1.01mm	1.04mm	0.35mm	0.40mm	6.40mm	6.50mm	7.90mm	8.00mm	1.00mm
EM	18.26mm	18.29mm	1.01mm	1.04mm	0.35mm	0.40mm	6.40mm	6.50mm	7.90mm	8.00mm	1.00mm
S	22.36mm	22.39mm	1.39mm	1.42mm	0.35mm	0.40mm	9.90mm	10.00mm	11.9mm	12.00mm	1.37mm
0	31.73mm	31.77mm	1.63mm	1.67mm	0.45mm	0.50mm	12.60mm	12.70mm	14.9mm	15.00mm	1.60mm
1	44.43mm	44.47mm	2.53mm	2.57mm	0.55mm	0.60mm	11.60mm	11.70mm	14.9mm	15.00mm	2.50mm